



# *DOORHAN*®

DOCKING SYSTEMS

QUALITY | RELIABILITY | SAFETY



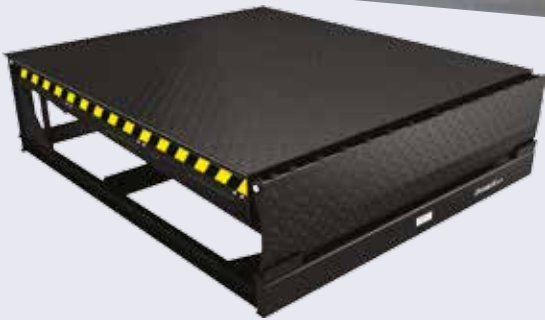

| Electrohydraulic with hinged lip of DLHI series

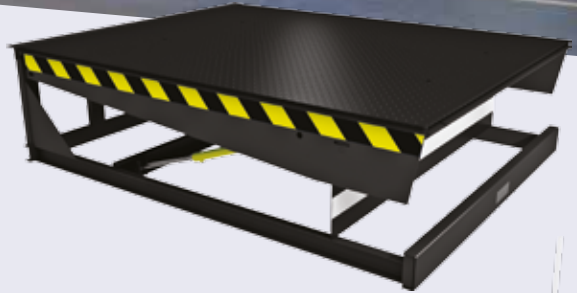

| Electrohydraulic with telescopic lip of DSI series



| Mechanical with hinged lip of MODL series

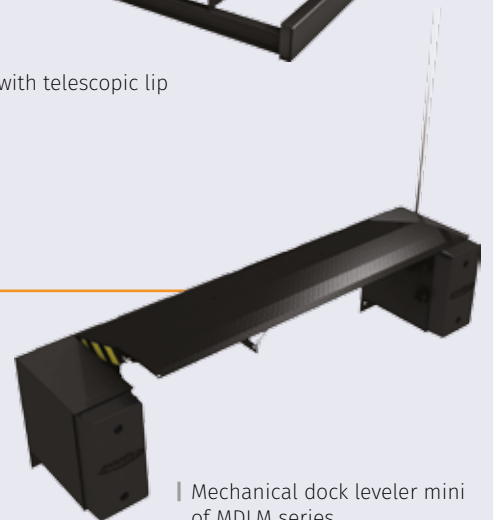

| Mechanical dock leveler mini of MDLM series

## DOCK LEVELERS

### WORKFLOW OPTIMIZATION

Dock levelers provide a smooth and a quick movement of forklifts between warehouses and trucks/trailers, during loading and unloading operations.

### WIDE MODEL RANGE

The variety of dock levelers allows you to choose the best option for any object.



| Dock Shelters with aluminum collapsible structure of DSHRT series



| Dock Shelters with aluminum non-collapsible structure of DSHRD series



| Inflatable Dock Shelters of DSHINF series

## DOCK SHELTERS

### ENERGY EFFICIENT

Dock Shelters are designed to provide maximum impermeability during loading and unloading, while maintaining the required microclimate of the facility.

### CONVENIENT OPERATION

During handling process the rear part of the truck or trailer may easily enter into the dock, thereby, making the operation simple and convenient.



| Dock Houses of standard series DHOU S



| Dock Houses of light series DHOU SL

## DOCK HOUSES

### A COMPREHENSIVE APPROACH

Dock Houses represent a complex structure which permits to install dock levelers and dock shelters in front of the building, while providing thermal insulation between the building and dock equipment.

### CONVENIENT SOLUTION

Dock Houses are available in four adjunction angles — 90, 60, 45 and 30°; therefore, allowing to be installed in areas where perpendicular parking of the truck/trailer to the dock is impossible.

# DOCK HOUSE LEVELERS

## SPACE SAVING

Dock House Levelers are designed to be installed outdoors and are indispensable in cases where it is necessary to maximize the use of storage space.

## CONVENIENT ACCESS

Dock House Levelers are intended to facilitate loading and unloading operations in areas where perpendicular parking of the trucks to the building is not provided.

| Stationary mechanical folding track with hinged lip



| Sliding mechanical folding track with hinged lip FT series

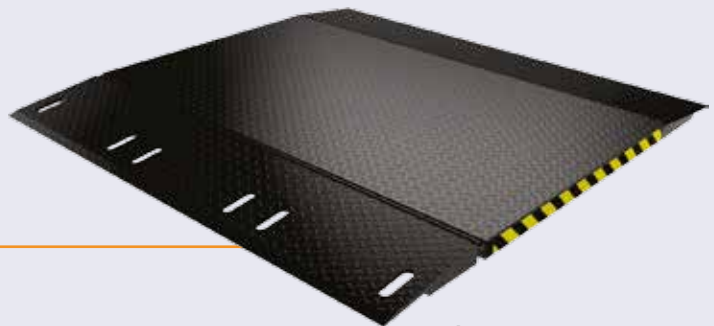

| Mobile track

# MECHANICAL FOLDING TRACKS

## EFFECTIVE SOLUTION

Mechanical Folding Tracks are intended for loading and unloading operations; are installed on open ramps, compensating the height difference between the truck and the dock of up to 360 mm.

## INDIVIDUAL APPROACH

Mechanical Folding Tracks can have a stationary or a sliding construction; while the Mobile Tracks are used for small loads.

# ACCESSORIES



## WHEEL GUIDES

Designed to minimize possible contact with the truck wheel rim, these accessories provide a guided and accurate truck parking at the dock. A choice of two types of installation is provided — using anchor bolts or concreting.



## GUARDS

Are designed to be installed indoors to prevent damages to the walls by forklifts or pallets and to ensure their correct and safe movement within the storage facility and near the dock.



## PROTECTION BOLLARDS

Shock columns are intended **or indoor use designed** protect vertical tracks of the doors from damages that may be caused by forklifts and pallets during operation.

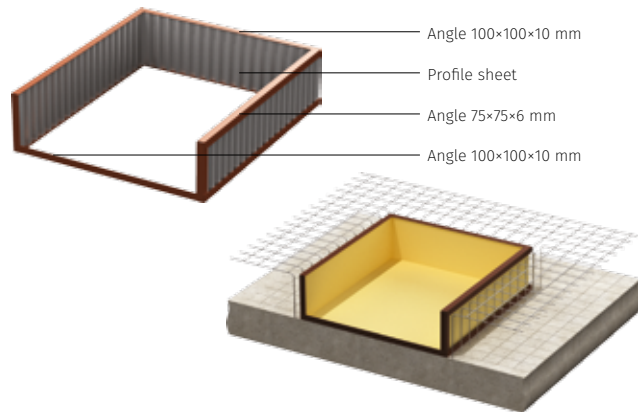

## FRAME FOR CONCRETING

Ensures proper installation of the dock leveler. The frame for concreting is manufactured according to the dock leveler dimensions.



## RUBBER BUMPERS

Provide a secure entrance of the trucks to the loading site and prevent the facility walls from damage, acting as a bumper. These accessories are made of a solid technical rubber, which increases their durability.

# TECHNICAL SPECIFICATIONS

## DOCK LEVELERS

Parameters	Electrohydraulic with hinged lip of DLHHI series	Electrohydraulic with telescopic lip of DSI series	Mechanical with hinged lip of MODL series	Mechanical dock leveler mini of MDLM series
Length [mm]	2500 / 3000 / 3500 / 4000 / 4500	2500 / 3000 / 3500 / 4000	2500	500
Width [mm]	1800 / 2000 / 2200	2000 / 2200 / 2400	1800 / 2000	1600 / 1800 / 2000 / 2200
Lip length [mm]	400 (500 upon request)	500/1 000	400	300 (400 on request)
Working range [mm]	from -350 to +550	from -430 to +480	from -300 to +310	from -100 to +100
Amount of lift cylinders [pcs]	1 (2 on request)	2		
Load capacity [kg]	6000 / 10000 other on request	6000 / 10000 other on request	6000	6000
Temperature range [°C]	-30...+50	-30...+50	-30...+50	-30...+50
Colour <sup>1</sup>	black (RAL 9005), other on request	black (RAL 9005), other on request	black (RAL 9005), other on request	black (RAL 9005), other on request

## DOCK SHELTERS

Parameters	Dock shelters with aluminum collapsible structure of DSHRT series	Dock shelters with non-collapsible structure of DSHRD series	Inflatable dock shelters of DSHINF series
Width [mm]	3000 / 3200 / 3400	3000 / 3200 / 3400	3410 / 3610
Height [mm]	3000 / 3200 / 3400 / 4400	3000 / 3200 / 3400 / 4400	3300 / 3800 / 4900
Depth [mm]	600 (900 on request)	600 (900 on request)	800 (other on request)
Upper sheet	1 (2 on request)	1 (2 on request)	1
Profile colour	white aluminum (RAL 9006) other colour on request	white aluminum (RAL 9006) other colour on request	white aluminum (RAL 9006) other colour on request
Colour of the side panels		white (RAL 9003) other colour on request	white (RAL 9003) other colour on request
Thickness of PVC sheet [mm]	3		3
Temperature range [°C]	-35...+50	-35...+50	-35...+50
Lengthening of top cushion [mm]			900 (1200 on request)
Lengthening of side cushion [mm]			600
Top decorative curtain			500
Side decorative curtain			250
Average time of filling the cushions			40
Cushion material thickness (Cordura 1000) [mm]			0,5

## DOCK HOUSES AND DOCK HOUSE LEVELERS

Parameters	Dock Houses standard DHOUS series	Dock Houses light DHOUSL series	Dock House Levelers of FEH and FET series
Dimensions	according to the dimensions of dock leveler and dock shelter	according to the dimensions of dock leveler and dock shelter	according to the dimensions of dock leveler and dock shelter
Angle	90 / 60 / 45 / 30° (other angle on request)	90 / 60 / 45 / 30° (other angle on request)	90 / 60 / 45 / 30° (other angle on request)
Walls	sandwich panels 40 mm / roll formed sheet C20/21	roll formed sheet C20/21	
Maximal wind load [kN/m <sup>2</sup> ]	065	065	
Roof	galvanized sheet C44	galvanized sheet C44	
Maximal snow load (roof) [kN/m <sup>2</sup> ]	30	30	
Outside/inside wall colour	white (RAL 9003), other on request	white (RAL 9003) / grey	
Frame colour <sup>1</sup>	black (RAL 9005), other on request	black (RAL 9005), other on request	black (RAL 9005), other on request
Wall edging profile colour	white aluminum (RAL 9006) other on request	white aluminum (RAL 9006) other on request	
Temperature range [°C]	-35...+50	-35...+50	-35...+50

## MECHANICAL FOLDING TRACKS

Parameters	Mechanical Folding Tracks	Mobile Track
Length [mm]	1000 / 1500	2000
Width [mm]	1200 / 1500 / 1800 / 2000	1800 / 2000
Lip length [mm]	210	410
Working range [mm]	-180...+180	0...240 (above the dock)
Maximal load [kg]	4000	4000
Temperature range [°C]	-30...+50	-30...+50
Colour <sup>1</sup>	black (RAL 9005), other on request	black (RAL 9005), other on request

<sup>1</sup> Powder painting with preliminary shot peening.

# MOBILE RAMPS

The speed of loading and unloading is a key parameter to assess the activity of warehouses. Mobile Ramps are the most effective solution enabling handling operations particularly at warehouses that lack loading docks. DoorHan Mobile Ramps are designed to provide forklift access from the ground to the truck/trailer and do not require special preparation to launch.

| Mobile ramp with support on truck

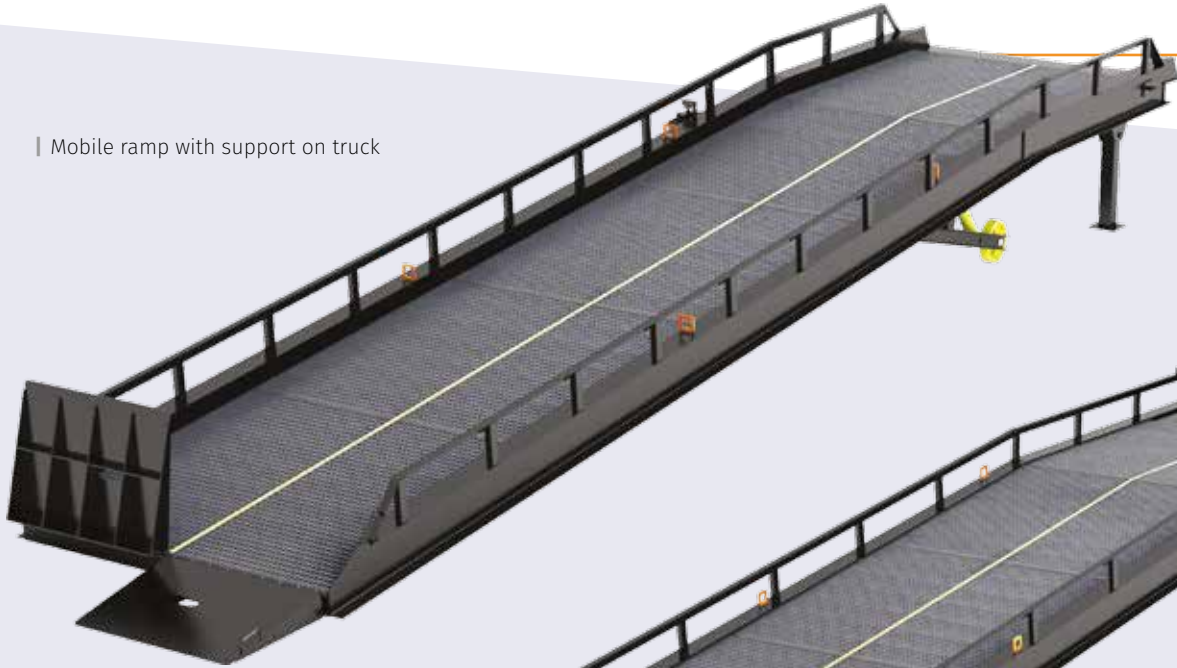

| Mobile ramp without support on truck



## TYPE OF LOADING

**Unilateral loading** - designed to work with one truck/trailer.

**Three lateral loading** - designed to load and unload up to three trucks/trailers simultaneously and transfer goods from one vehicle to another.

## TYPE OF SUPPORT

**Ramps without support** on the vehicle which have their own support. Due to this, the weight of the ramp and forklift with goods does not lie on the vehicle body. Height variations between the ramp and the truck trailer are compensated by a hinged lip.

**Ramps with support** on the vehicle which completely follows truck height during loading and unloading operations.

## OPERATOR TYPE

- Manual hydraulic operator.
- Just lift mechanism.
- Electro hydraulic operator.

## CARRIAGEWAY MATERIAL

- Galvanized grill.
- Expanded metal sheet.



| Mobile ramp with three lateral load

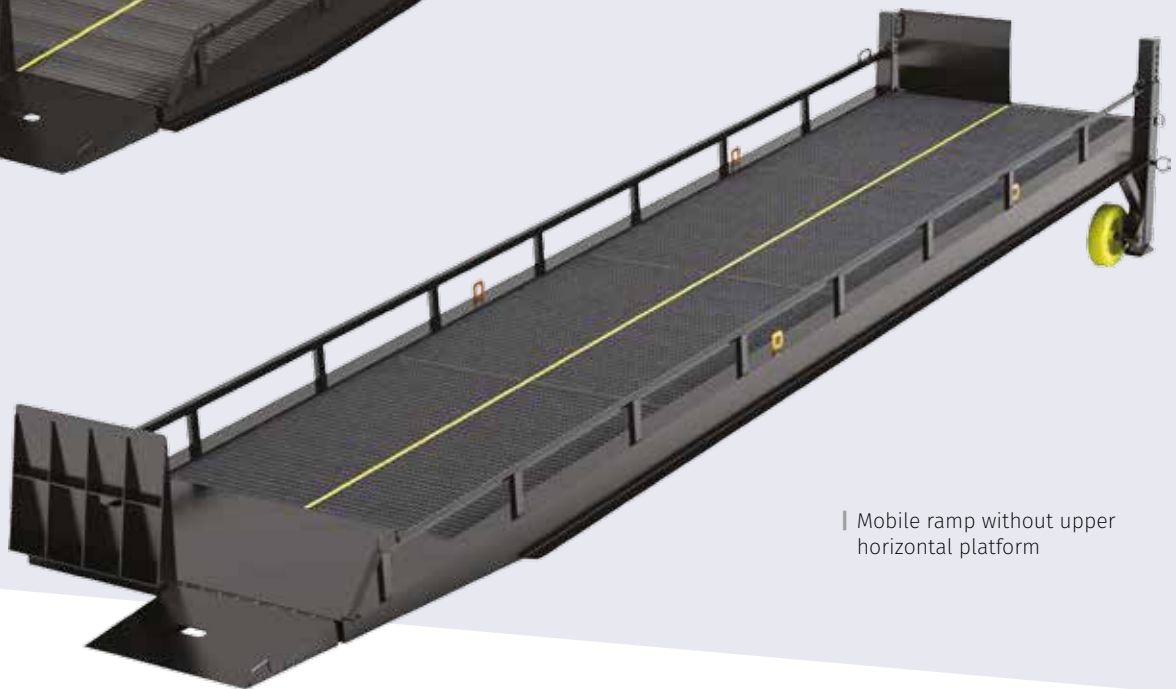
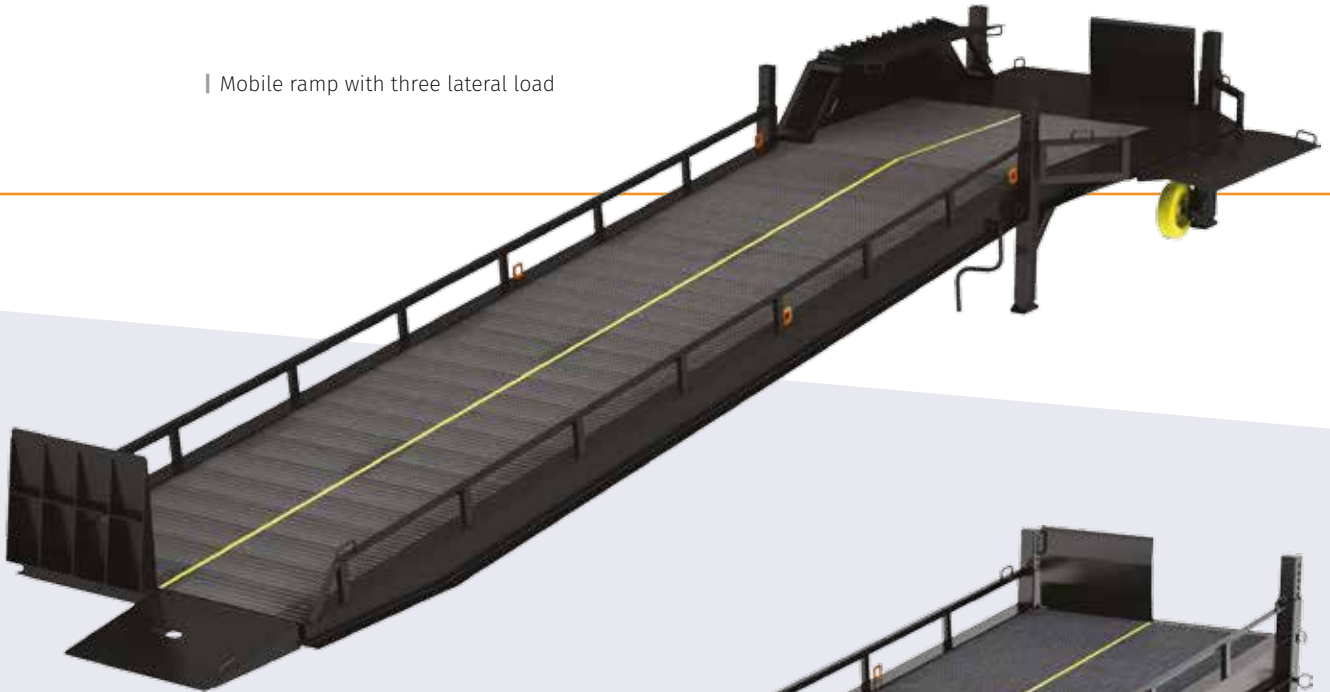

| Mobile ramp without upper horizontal platform

## DOORHAN OFFERS FOUR BASIC MODELS OF MOBILE RAMPS OF RM SERIES

- with support on truck;
- without support on truck;
- with three lateral load;
- without upper horizontal platform.

Combinations of operator type and carriageway material are available for all mobile ramp models. There is also possibility to manufacture mobile ramps according to individual needs.

All mobile ramps work on a similar principle. The ramp is raised by a mechanical or hydraulic operator, equipped with a safety system, and is easily moved by a forklift to the required loading/unloading area. The mobile ramp with support on truck is installed on the vehicle body while the mobile ramp with its own support is installed on the support. After operation is complete, the ramp is raised and is transported back to the storage area using a forklift.

# MOBILE RAMP WITH SUPPORT ON TRUCK

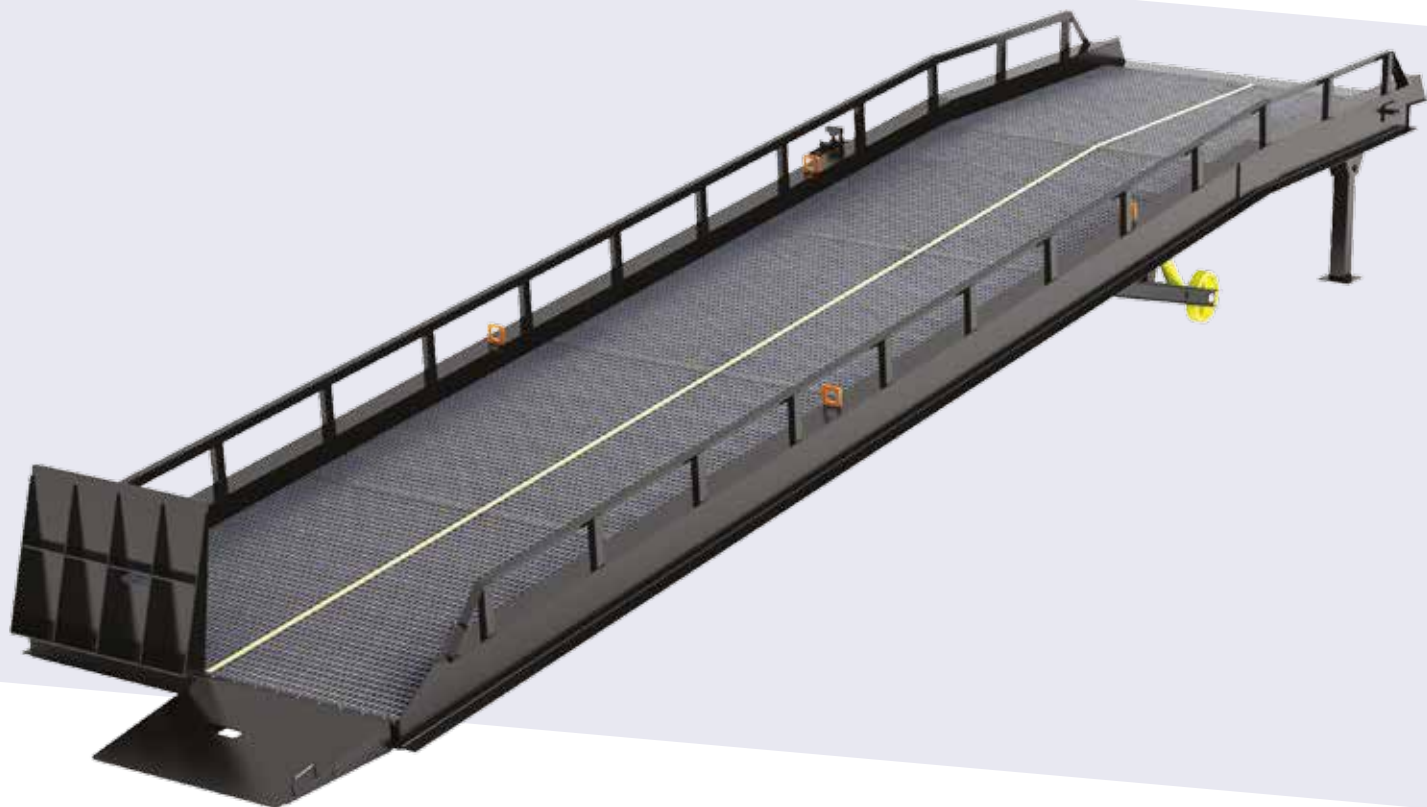

Design features: support on the truck; can be used with electro hydraulic operators, as well as with manual hydraulic operators.

Technical Specifications	
Length	12000 mm
Width	2200 mm
Length of horizontal part	2000 mm
Carriageway width	1900 mm
Working range	900 – 1500 mm
Number of lift cylinders	2
Load capacity	7000 kg (70 kN) / 10000 kg (100 kN)
Maximum point load	1,3 N/mm <sup>2</sup> ; on request – 6,5 N/mm <sup>2</sup>
Power of the hydraulic pump operator (electro hydraulic mobile ramp)	1,5 kW
Power supply (electro hydraulic mobile ramp)	380 V, 3-phase
Control voltage (electro hydraulic ramp)	24 V
Protection class (electro hydraulic ramp)	IP54
Lubrication	low temperature oil STATOIL Hydraulic 131
Temperature range	-30...+50 °C
Weight	2525 kg
Colour (enamelled)	black (RAL 9005), other on request
Surface cleaning class before painting	Sa2

# DIMENSIONS

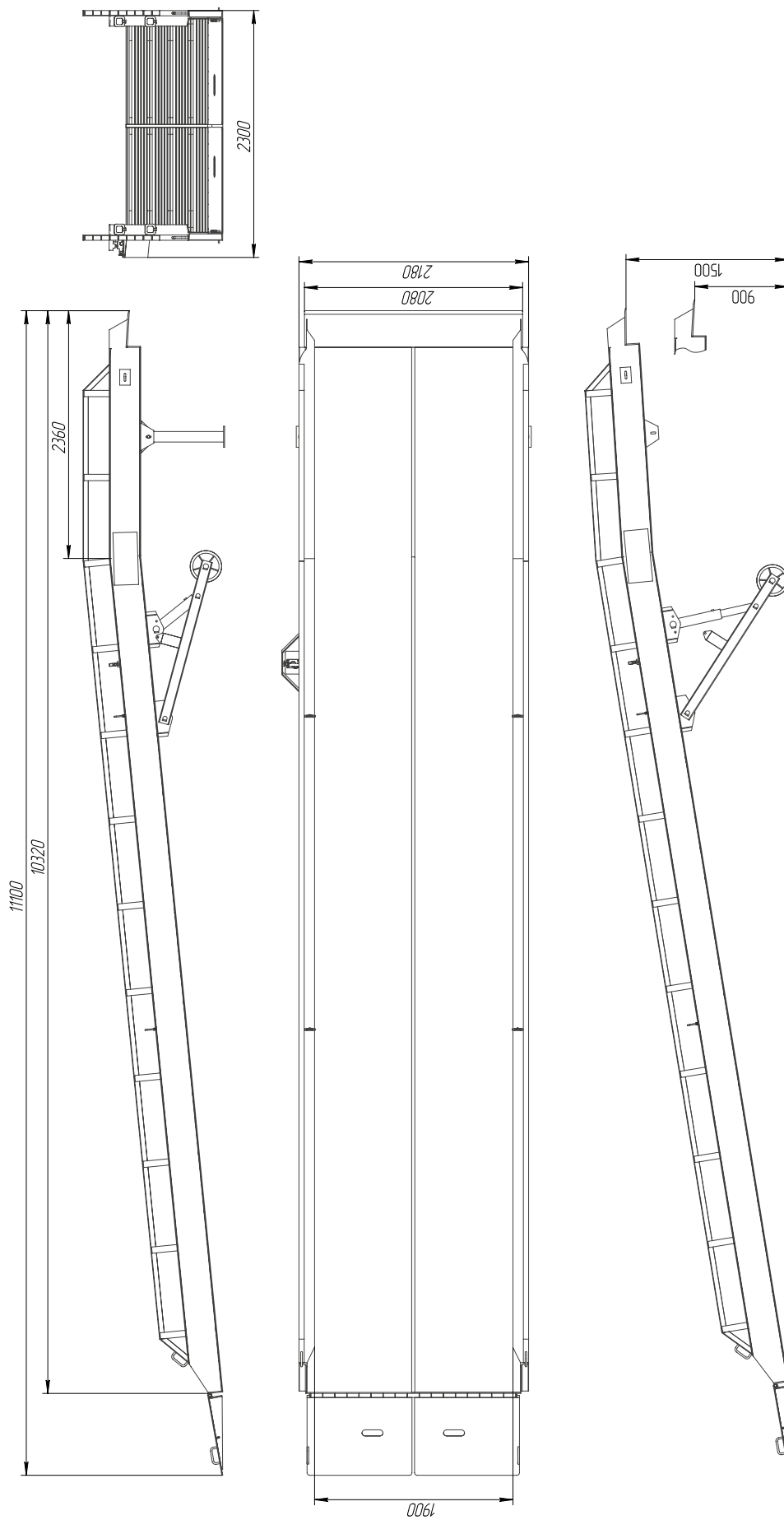

# MOBILE RAMP WITHOUT SUPPORT ON TRUCK



Design features: support on the ground; front hinged lips; can be used with electro hydraulic operators, manual hydraulic operators and mechanical operators.

Technical Specifications	
Length	12000 mm
Width	2200 mm
Length of horizontal part	3000 mm
Carriageway width	1900 mm
Working range	1100 – 1700 mm
Number of lift cylinders	2
Load capacity	7000 kg (70 кН) / 10000 kg (100 кН)
Maximum point load	1,3 N/mm <sup>2</sup> ; on request – 6,5 N/mm <sup>2</sup>
Power of the hydraulic pump operator (electro hydraulic mobile ramp)	1,5 kW
Power supply (electro hydraulic mobile ramp)	380 V, 3-phase
Control voltage (electro hydraulic ramp)	24 V
Protection class (electro hydraulic ramp)	IP54
Lubrication	low temperature oil STATOIL Hydraulic 131
Temperature range	-30...+50 °C
Weight	2975 kg
Colour (enamelled)	black (RAL 9005), other on request
Surface cleaning class before painting	Sa2

# DIMENSIONS

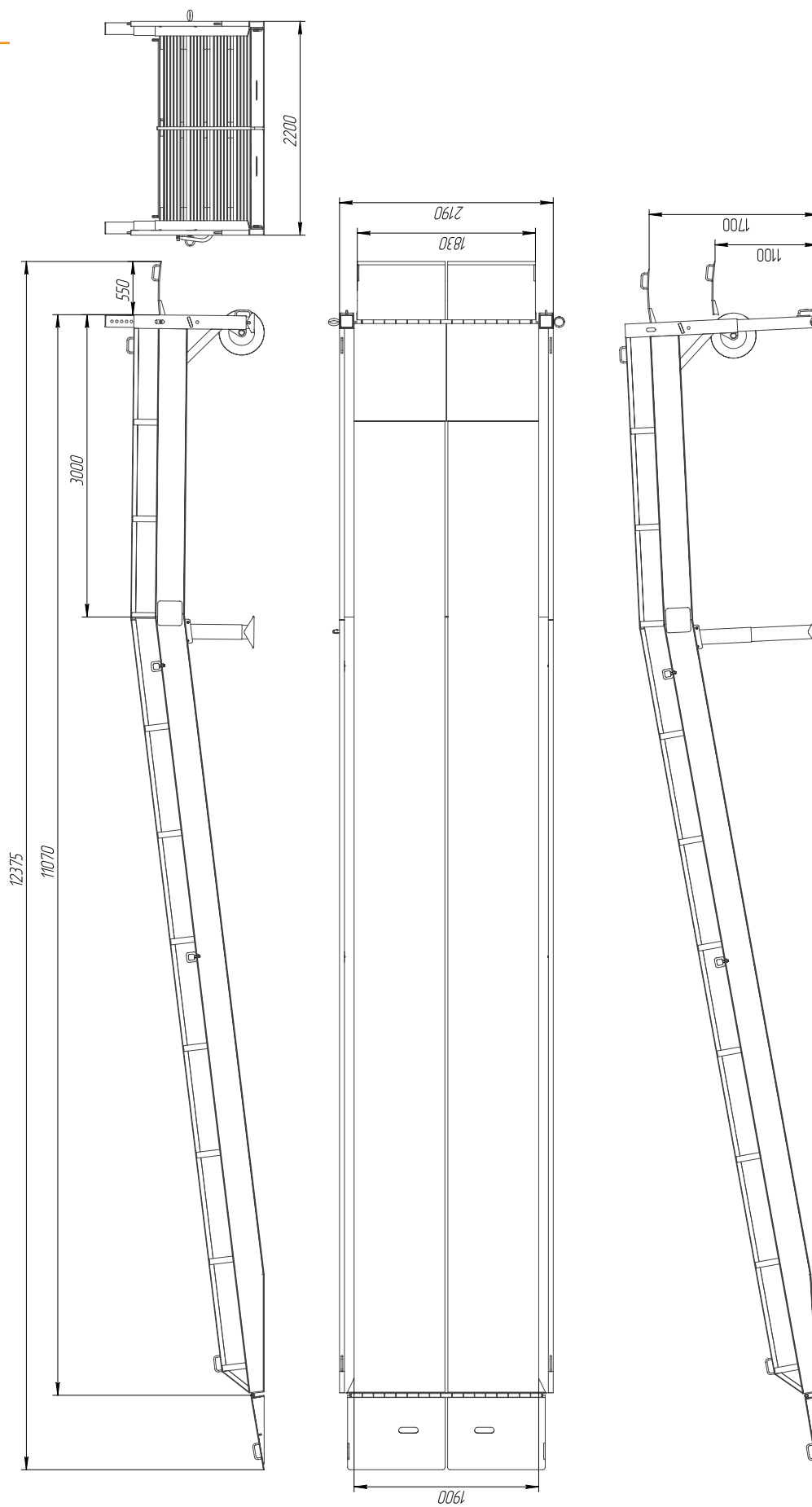

# MOBILE RAMP WITH THREE LATERAL LOAD



Design features: support on the ground; loading/unloading on three sides; front and side hinged lips; can be used with electro hydraulic operators, manual hydraulic operators and mechanical operators.

Technical Specifications	
Length	12000 mm
Width	2200 mm
Length of horizontal part	3000 mm
Carriageway width	1900 mm
Working range	1100 – 1700 mm
Number of lift cylinders	2
Load capacity	7000 kg (70 кН) / 10000 kg (100 кН)
Maximum point load	1,3 N/mm <sup>2</sup> ; on request – 6,5 N/mm <sup>2</sup>
Power of the hydraulic pump operator (electro hydraulic mobile ramp)	1,5 kW
Power supply (electro hydraulic mobile ramp)	380 V, 3-phase
Control voltage (electro hydraulic ramp)	24 V
Protection class (electro hydraulic ramp)	IP54
Lubrication	low temperature oil STATOIL Hydraulic 131
Temperature range	-30...+50 °C
Weight	2975 kg
Colour (enamelled)	black (RAL 9005), other on request
Surface cleaning class before painting	Sa2

# DIMENSIONS

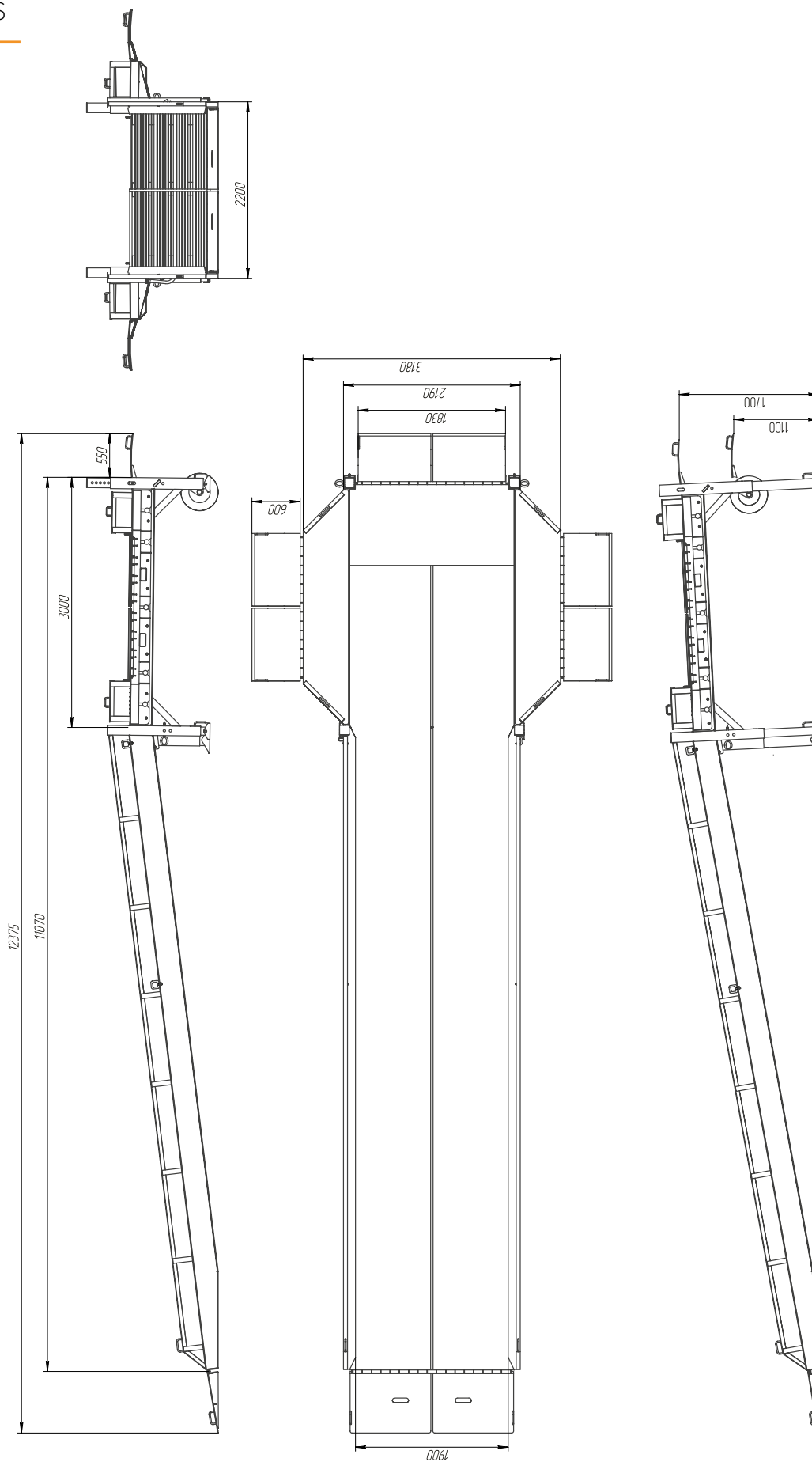

# MOBILE RAMP WITHOUT UPPER HORIZONTAL PLATFORM

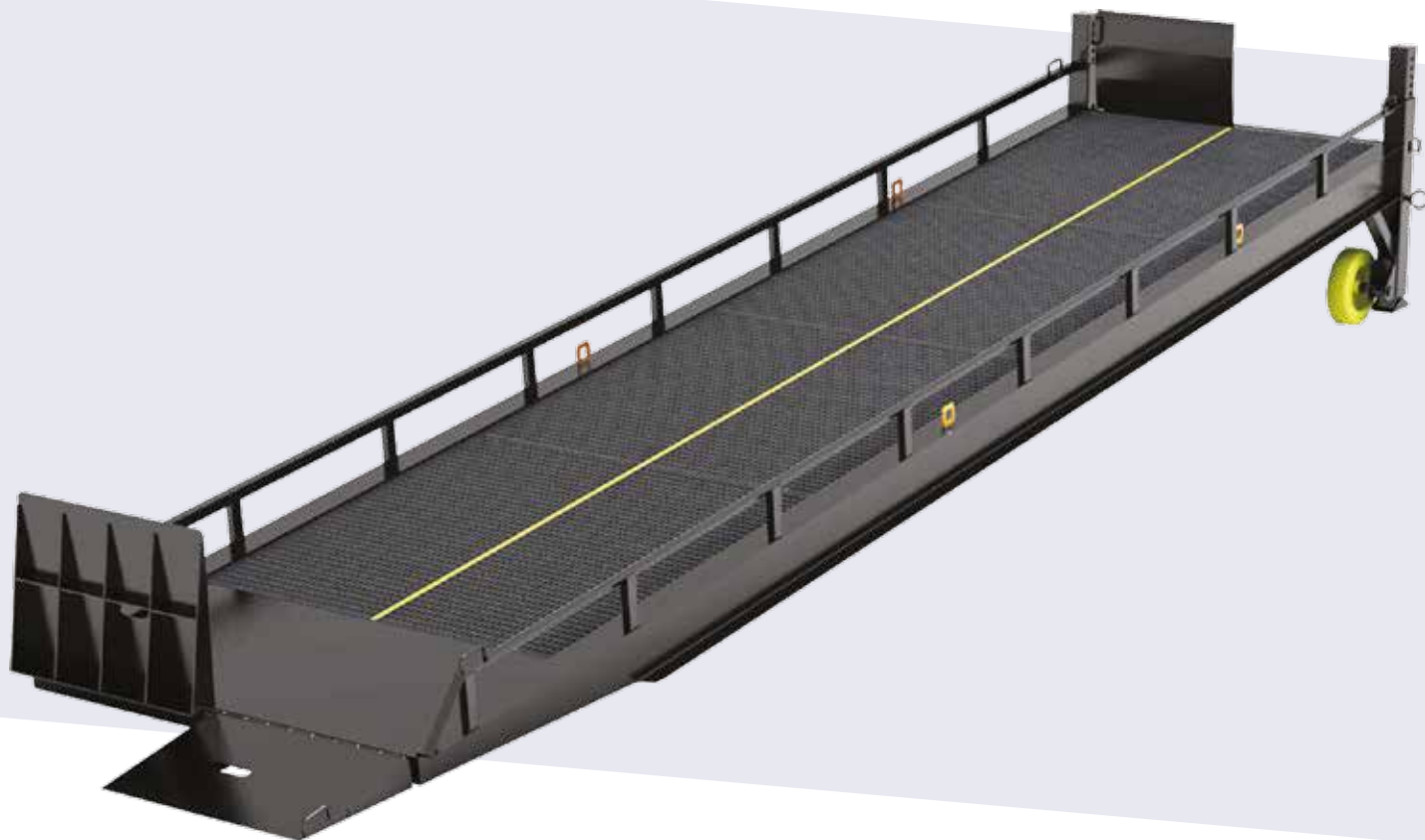

Design features: support on the ground; front hinged lips; without horizontal platform;  
can be used with electro hydraulic operators, manual hydraulic operators and mechanical operators.

Technical Specifications	
Length	9000 mm
Width	2200 mm
Carriageway width	1900 mm
Working range	1100 – 1600 mm
Number of lift cylinders	2
Load capacity	7000 kg (70 kN) / 10000 kg (100 kN)
Maximum point load	1,3 N/mm <sup>2</sup> ; on request — 6,5 N/mm
Power of the hydraulic pump operator (electro hydraulic mobile ramp)	1,5 kW
Power supply (electro hydraulic mobile ramp)	380 V, 3-phase
Control voltage (electro hydraulic ramp)	24 V
Protection class (electro hydraulic ramp)	IP54
Lubrication	low temperature oil STATOIL Hydraulic 131
Temperature range	-30...+50 °C
Weight	2410 kg
Colour (enamelled)	black (RAL 9005), other on request
Surface cleaning class before painting	Sa2



# DIMENSIONS

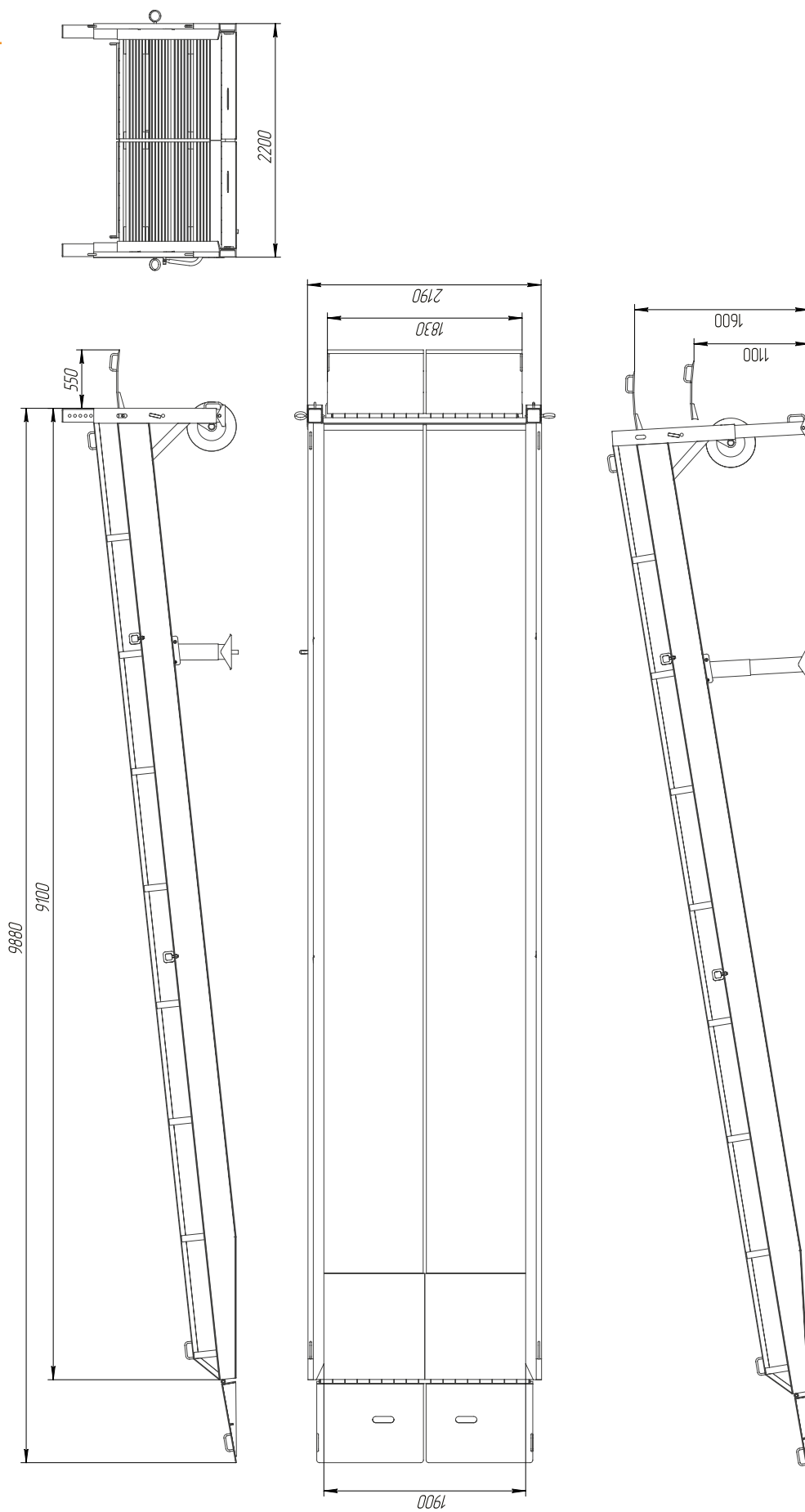

# LIFT TABLES

Modern hydraulic lift tables are used to lift and to lower loads at different levels. Lift tables ensure a quick and convenient vertical load transfer, are reliable and easy to maintain. Lift tables can be used to lift and lower vehicles at multilevel parkings and at production lines, for order picking, work positioning and assembly as well as an alternative of freight elevators or stationary ramps to load and unload trucks.

## CONSTRUCTION

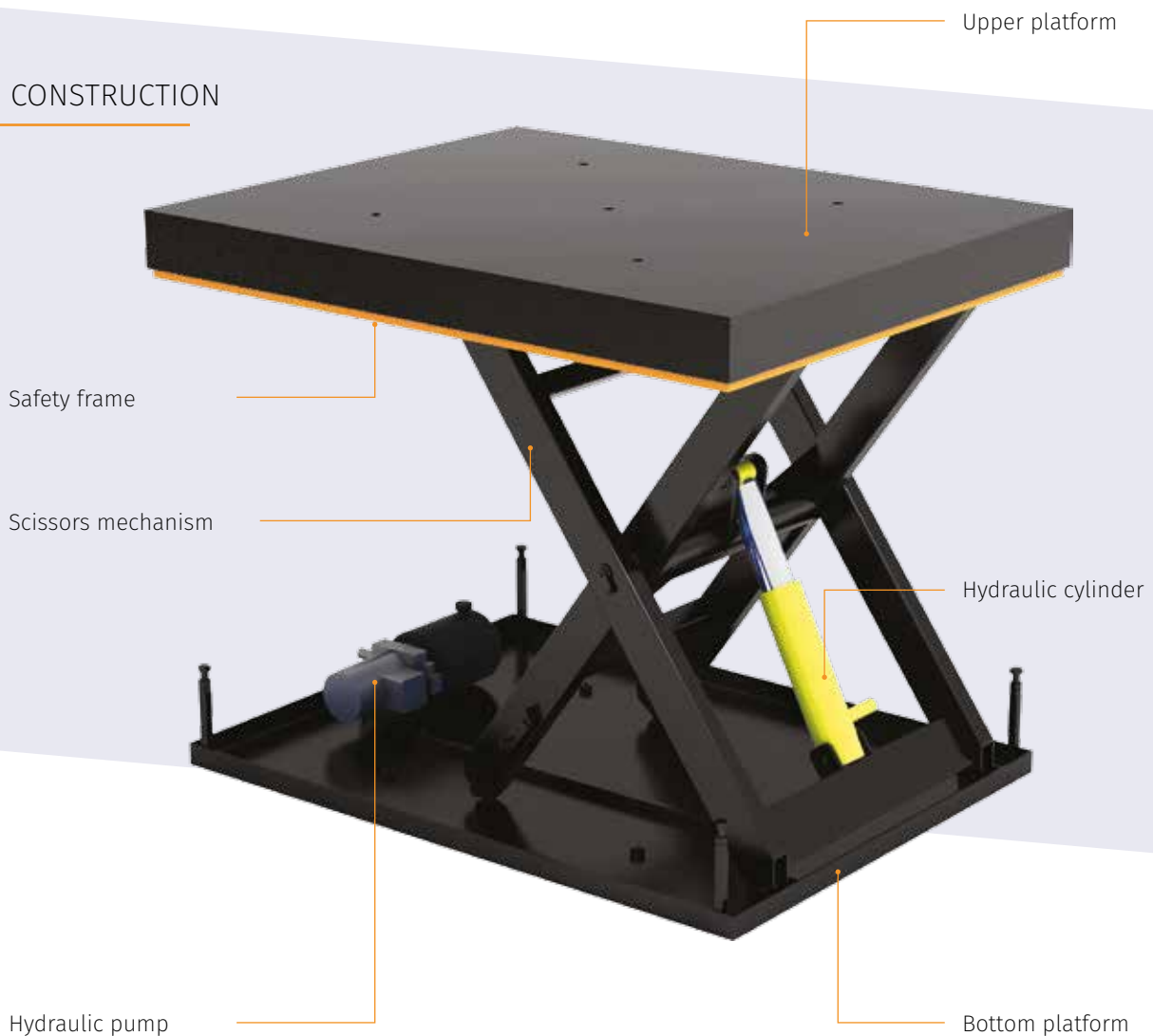

Hydraulic pump can be placed either inside on the bottom or outside. Lift table operation is carried out by a portable push-button remote control (24 V control system ). Lift tables are supplied with safety frames and valves, as well as with mechanical supports. The safety frame designed to stop the table movement when the upper platform meets an obstacle, is located around

the platform perimeter. This safety mechanism provides protection against personnel injury, which is especially important when the lift table is installed in the pit. Each lifting cylinder has a built-in safety valve, which lowers the table at a rate not exceeding 0.15 m/s, in case when hydraulic tubes break. Also, it has folding table supports which are used at maintenance.

Technical Specifications	
Operator power of hydraulic pump	according to the lift table dimensions
Supply voltage	380 V, 3-phase
Control voltage	24 V
Protection class	IP54
Lubrication	low temperature oil STATOIL Hydraulic 131
Temperature range	-30...+50 °C
Weight	according to the lift table parameters

## DOORHAN OFFERS FOUR TYPES OF LIFT TABLES OF LT SERIES

- single scissor lifts;
- double scissor lifts;
- triple scissor lifts;
- tandem scissor lifts.

## LOAD DISTRIBUTION

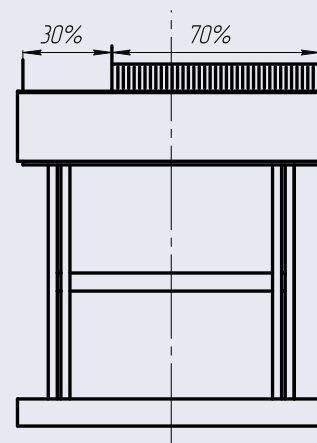
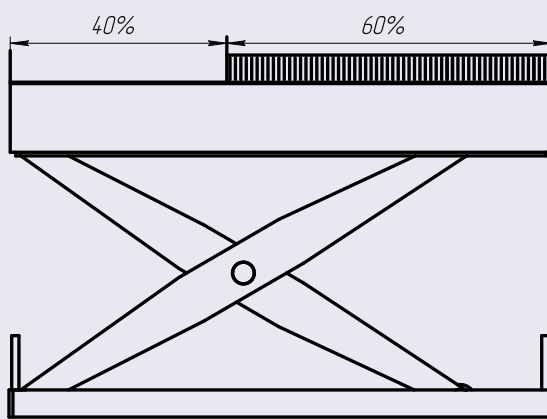

## LIFT TABLES MARKING

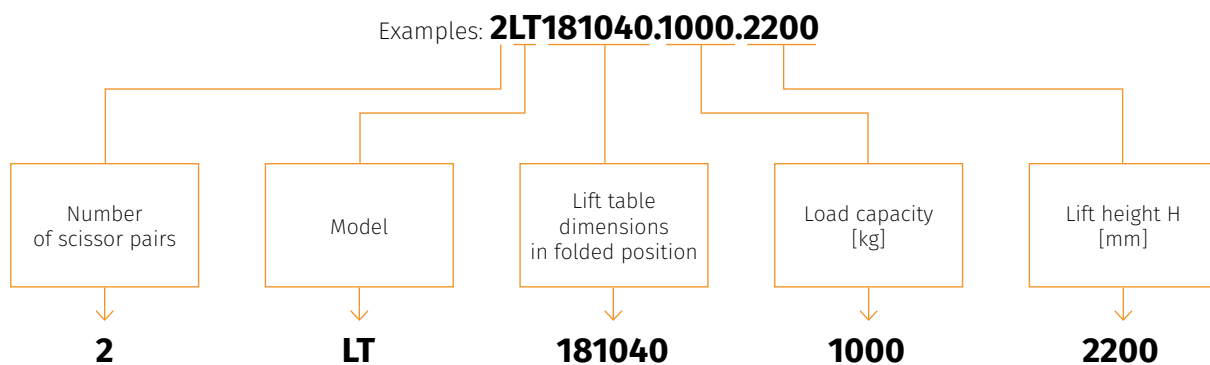

If at the end of the line stands letter „E“, the hydraulic station is positioned outside.

# SINGLE SCISSOR LIFTS



Article	Load capacity [kg]	Length [mm]	Width [mm]	Height Hmin [mm]	ΔH working [mm]	Number of hydraulic cylinders	Elevating time t [sec.]	Power N [kW]
LT201235.1000.1300	1 000	2 000	1 200	350	1 300	1	36	0,75
LT202035.1000.1300	1 000	2 000	2 000	350	1 300	1	36	0,75
LT251535.1000.1400	1 000	2 500	1 500	350	1 400	1	38	0,75
LT252035.1000.1400	1 000	2 500	2 000	350	1 400	1	38	0,75
LT202040.2000.1300	2 000	2 000	2 000	400	1 300	1	23	2,2
LT251540.2000.1400	2 000	2 500	1 500	400	1 400	1	23	2,2
LT252040.2000.1400	2 000	2 500	2 000	400	1 400	1	23	2,2
LT302040.2000.1400	2 000	3 000	2 000	400	1 400	1	23	2,2
LT302440.2000.1400	2 000	3 000	2 400	400	1 400	1	23	2,2
LT352040.2000.1400	2 000	3 500	2 000	400	1 400	2	47	2,2
LT352440.2000.1400	2 000	3 500	2 400	400	1 400	2	47	2,2
LT202040.3000.1300	3 000	2 000	2 000	400	1 300	2	47	2,2
LT251550.3000.1400	3 000	2 500	1 500	500	1 400	2	47	2,2
LT252050.3000.1400	3 000	2 500	2 000	500	1 400	2	47	2,2
LT302050.3000.1400	3 000	3 000	2 000	500	1 400	2	47	2,2
LT302450.3000.1400	3 000	3 000	2 400	500	1 400	2	47	2,2
LT352050.3000.1400	3 000	3 500	2 000	500	1 400	2	47	2,2
LT352450.3000.1400	3 000	3 500	2 400	500	1 400	2	47	2,2
LT402050.3000.1400	3 000	4 000	2 000	500	1 400	2	47	2,2
LT402450.3000.1400	3 000	4 000	2 400	500	1 400	2	47	2,2

# DOUBLE SCISSORS LIFTS

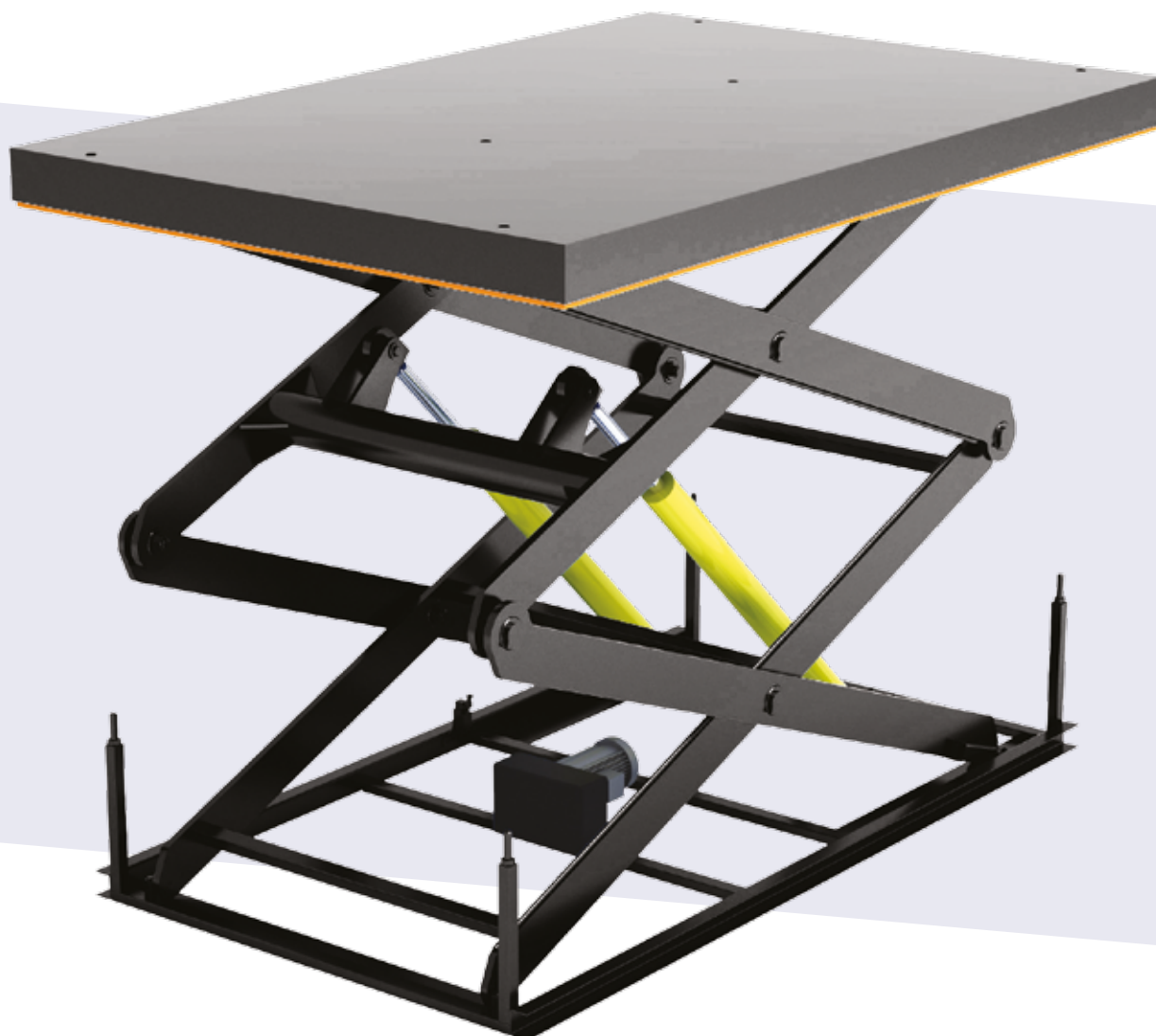

Article	Load capacity [kg]	Length [mm]	Width [mm]	Height Hmin [mm]	ΔH working [mm]	Number of hydraulic cylinders	Elevating time t [sec.]	Power N [kW]
2LT131035.500.1500	500	1 300	1 000	350	1 500	1	26	0,75
2LT181040.1000.2200	1 000	1 800	1 000	400	2 200	1	35	2,2
2LT181240.1000.2200	1 000	1 800	1 200	400	2 200	1	35	2,2
2LT201240.1000.2200	1 000	2 000	1 200	400	2 200	1	35	2,2
2LT221245.1000.2800	1 000	2 200	1 200	450	2 800	1	43	2,2
2LT221545.1000.2800	1 000	2 200	1 500	450	2 800	1	52	2,2
2LT222045.1000.2800	1 000	2 200	2 000	450	2 800	1	52	2,2
2LT301265.2000.3600	2 000	3 000	1 200	650	3 600	2	123	2,2
2LT301565.2000.3600	2 000	3 000	1 500	650	3 600	2	123	2,2
2LT302065.2000.3600	2 000	3 000	2 000	650	3 600	2	123	2,2
2LT301275.3000.3600	3 000	3 000	1 200	750	3 600	2	123	2,2
2LT301575.3000.3600	3 000	3 000	1 500	750	3 600	2	123	2,2
2LT302075.3000.3600	3 000	3 000	2 000	750	3 600	2	123	2,2

# TRIPLE SCISSOR LIFTS



Article	Load capacity [kg]	Length [mm]	Width [mm]	Height Hmin [mm]	ΔH working [mm]	Number of hydraulic cylinders	Elevating time t [sec.]	Power N [kW]
3LT151070.500.2700	500	1 500	1 000	700	2 700	1	47	0,75
3LT151270.500.2700	500	1 500	1 200	700	2 700	1	47	0,75
3LT181265.1000.3400	1 000	1 800	1 200	650	3 400	1	68	0,75
3LT181565.1000.3400	1 000	1 800	1 500	650	3 400	1	68	0,75
3LT201265.1000.3400	1 000	2 000	1 200	650	3 400	1	68	0,75
3LT251563.1000.4500	1 000	2 500	1 500	630	4 500	1	91	0,75
3LT201283.2000.3800	2 000	2 000	1 200	830	3 800	2	68	2,2
3LT201583.2000.3800	2 000	2 000	1 500	830	3 800	2	68	2,2
3LT251583.2000.4500	2 000	2 500	1 500	830	4 500	2	91	2,2

# TANDEM SCISSOR LIFTS

---

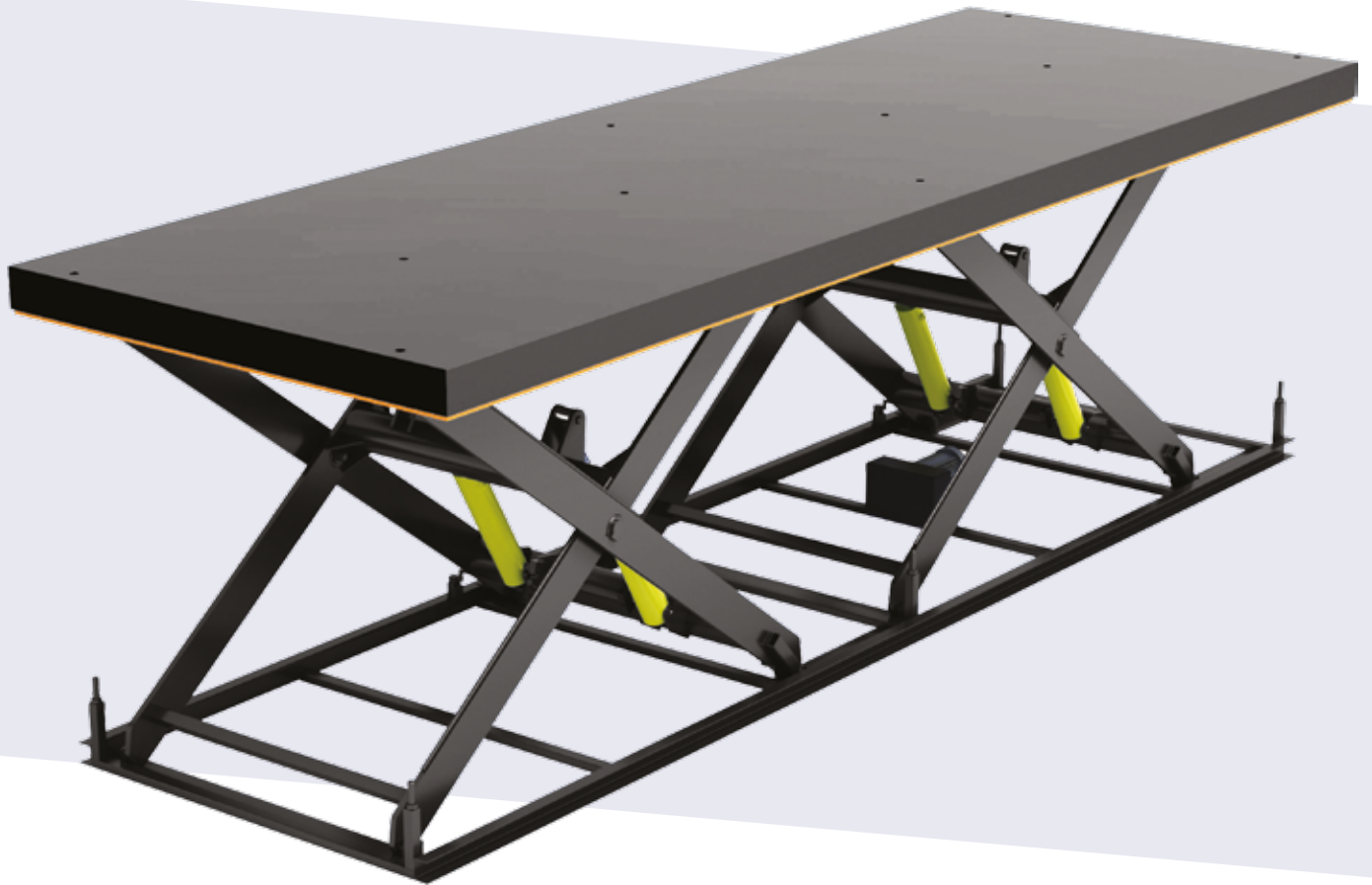

Tandem scissor lifts are produced according to individual requests.



# *DOORHAN*®

***DOORHAN***®

CZECH REPUBLIC  
KADAŇ

432 01, Královský Vrch 2018  
Tel.: +420 474 319 111  
E-mail: [kadan@doorhan.com](mailto:kadan@doorhan.com)  
[www.doorhan.com](http://www.doorhan.com) | [www.doorhan.cz](http://www.doorhan.cz)

